

Industrial/Redevelopment Opportunity

465 Bishop St NW | Atlanta, GA 30318

Offering Memorandum



MATTHEWS™

Exclusively Listed By



Thomas Wilkinson

Senior Associate

(404) 348-4945

thomas.wilkinson@matthews.com

License No. 416083 (GA)



Harrison Auerbach

SVP & Director

(404) 445-1092

harrison.auerbach@matthews.com

License No. 451527 (GA)

Maxx Bauman

Broker of Record

Broker Firm No. 80041 (GA)

Broker License No. 451849 (GA)

Table of Contents

03 | **Property
Overview**

10 | **Market
Overview**

MATTHEWS™



Property Highlights

Infill Atlanta Asset with True Covered Land Characteristics

465 Bishop St NW offers investors the opportunity to acquire a ±37,000 SF industrial facility on ±1.65 acres in one of Atlanta's most dynamic in-town corridors. With increasing surrounding density driven by nearby multifamily and mixed-use development, the property presents a compelling opportunity to control a well-located site with both current utility and long-term redevelopment upside.

Positioned in a Rapidly Transforming Urban Submarket

The surrounding area has seen a wave of new residential and mixed-use projects, alongside continued industrial activity, fundamentally reshaping the corridor. This blend of uses is driving land values and creating a path toward higher-and-better uses over time, while still supporting industrial occupancy in the near term.

Functional Improvements Supporting Interim Use or Hold Strategy

The existing masonry building features 14'-16'5" clear heights, three dock-high doors, and one grade-level door, providing a functional configuration for a variety of warehouse, service, or light industrial users. The building's layout and loading capabilities allow for continued occupancy while ownership evaluates longer-term strategic options for the site.

Flexible Site with Balanced Coverage and Usability

Situated on ±71,874 SF (±1.65 acres) with 51.48% site coverage, the property offers a functional balance between building area and yard space. This configuration supports current operations while also providing flexibility for future site reconfiguration, expansion, or alternative use scenarios.

Exceptional In-Town Connectivity with Favorable Demographics

The property benefits from immediate access to I-75 and I-85, placing it within minutes of Atlanta's core demand drivers. The surrounding submarket is supported by a dense in-town population exceeding 170,659 residents within a 3-mile radius, with average household incomes surpassing \$123,355 and annual consumer spending in the billions.



Property Overview

\$6,200,000
List Price

\$167.57
Price Per SF



465 Bishop St NW, Atlanta, GA 30318

Parcel	17 014800030145
MSA	Atlanta
Total Building Square Feet	±37,000
Total Acreage	±1.65
Lot Square Feet	±71,874
Building/Lot Coverage	±51.48%
Clear Height	14'-16'5"
Construction	Masonry
County	Fulton
Zoning	M1 (Light Industrial)
Office SF %	25%
Year Built	1945
Dock Doors	3 (12'x12')
Grade Level Doors	1 (12'x12')

Exterior Photos



| Interior Photos



Interior Photos

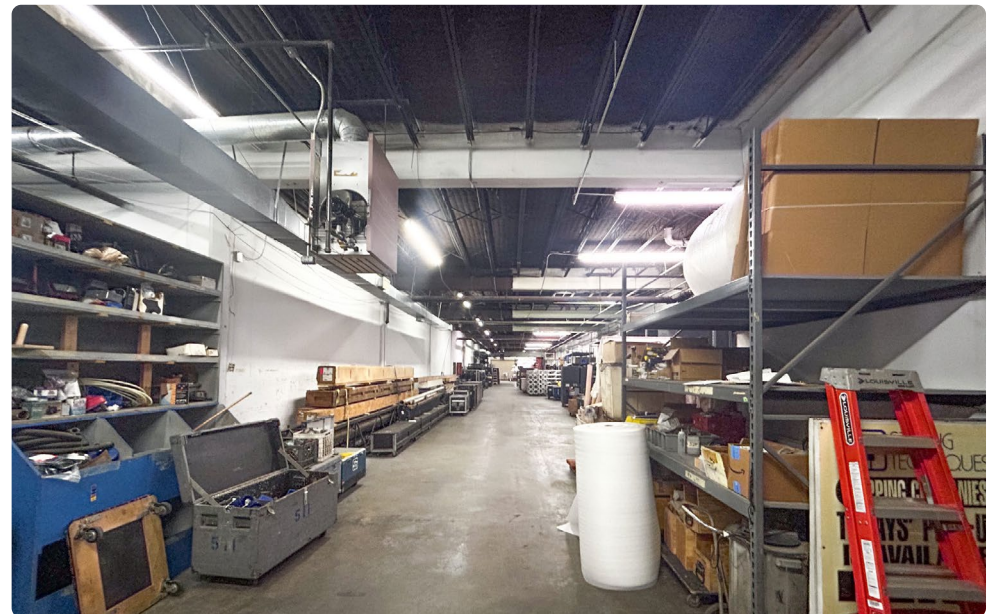

Floor Plans

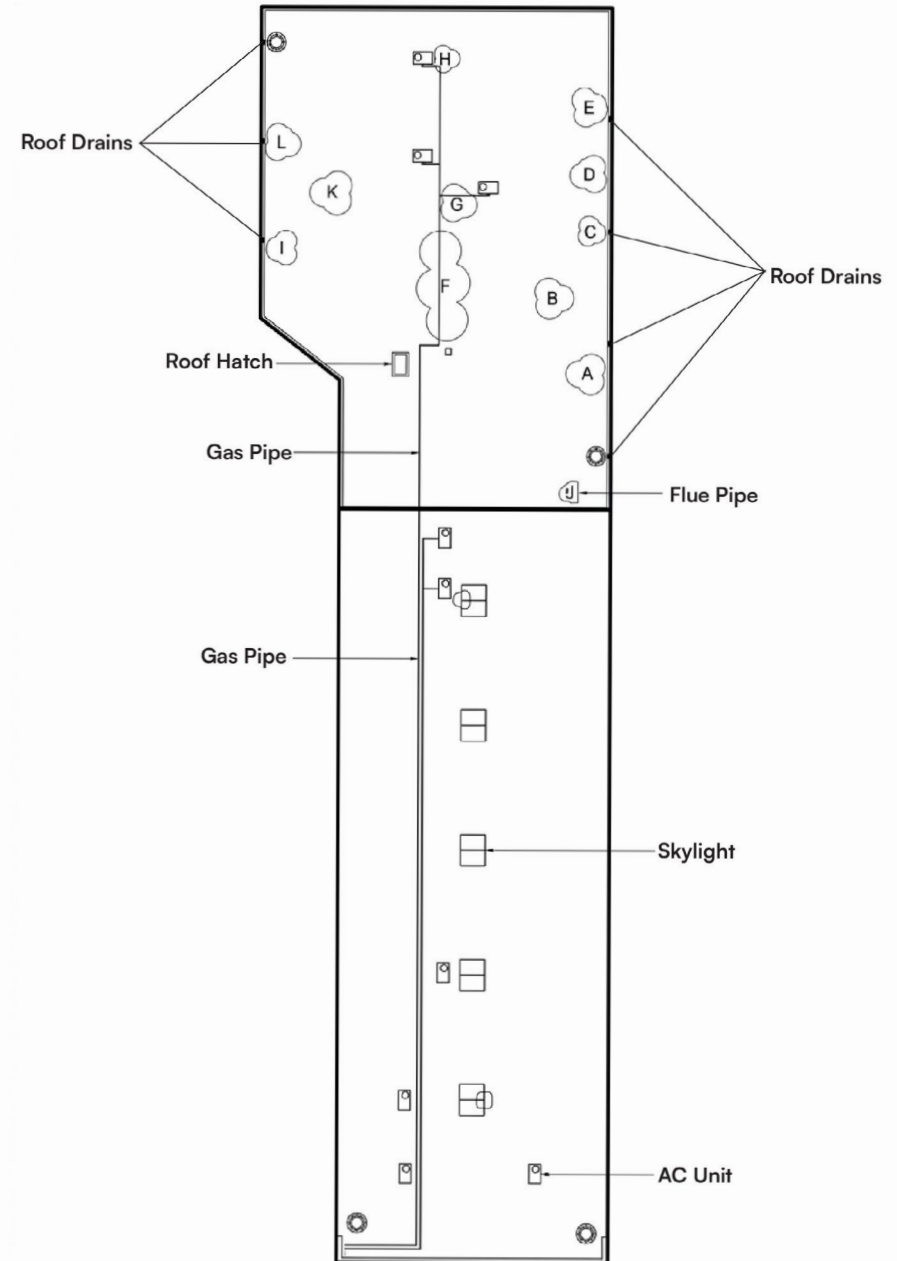
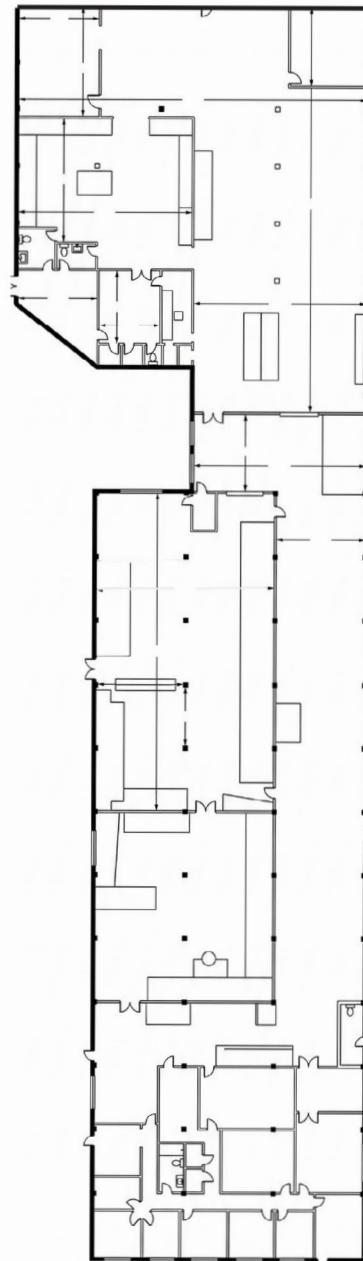
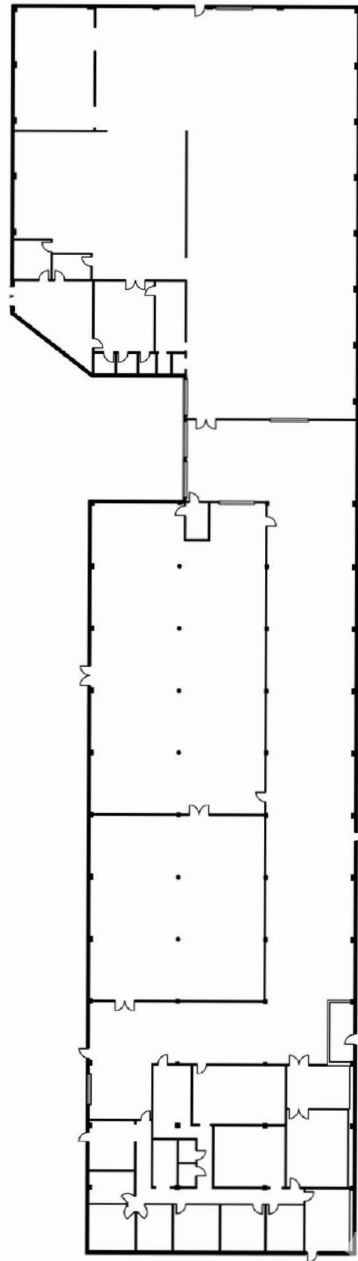



The Works Redevelopment
80-Acre Mixed-Use Adaptive Reuse Including Retail, Food Hall, Office, Residential

Subject Property

400 Bishop Street
Mixed-Use Redevelopment - 10-story building with residential + ground-floor live-work units

Goat Farm Redevelopment
Adaptive Reuse + Multifamily + Retail/Arts Redevelopment

Star Metals District Redevelopment
Star Metals Offices + Apartments + Food Hall/Retail

Midtown West / Howell Mill
Retail + Office + Adaptive Reuse (with surrounding residential growth).

Westside Paper Redevelopment
50+ Acre Mixed-Use Adaptive Reuse Including Residential, Retail, restaurants, brewery, event space (open)

665 Marietta Redevelopment
Planned multifamily, student housing, hotel, retail, and innovation space

Atlantic Station / Loring Heights Infill Wave
Multiple mid-rise developments targeting walkable live-work-play

±19,400 VPD

±141,000 VPD



Market Overview

Staging Techniques
465 Bishop St NW | Atlanta, GA



Market Overview

Nearby Developments

- 1 Westside Union**
 - 273-unit multifamily development delivered in 2024–2025
 - Modern Class A product featuring rooftop amenities and integrated retail
 - Reinforces Bishop Street as a growing residential corridor with walkable density
- 2 The Works**
 - 80-acre mixed-use campus anchoring the Upper Westside submarket
 - Includes:
 - ~500K SF office
 - ~350K SF retail
 - Multifamily residential components
 - Serves as a major destination for dining, retail, and employment
- 3 Star Metals District**
 - Prominent mixed-use development in the heart of West Midtown
 - Features:
 - Class A office tower
 - Luxury residential tower
 - Curated retail and restaurant offerings
 - Established as a live-work-play hub attracting creative and tech tenants

Property Demographics

POPULATION	1-MILE	3-MILE	5-MILE
2020 Population	24,391	170,659	366,830
2025 Population	26,646	186,868	401,121
2030 Population Projection	27,745	194,650	417,279
HOUSEHOLDS	1-MILE	3-MILE	5-MILE
2020 Households	12,846	82,749	177,412
2025 Households	14,186	91,788	194,729
2030 Household Projections	14,807	95,879	202,797
INCOME	1-MILE	3-MILE	5-MILE
Avg Household Income	\$123,355	\$132,106	\$129,140

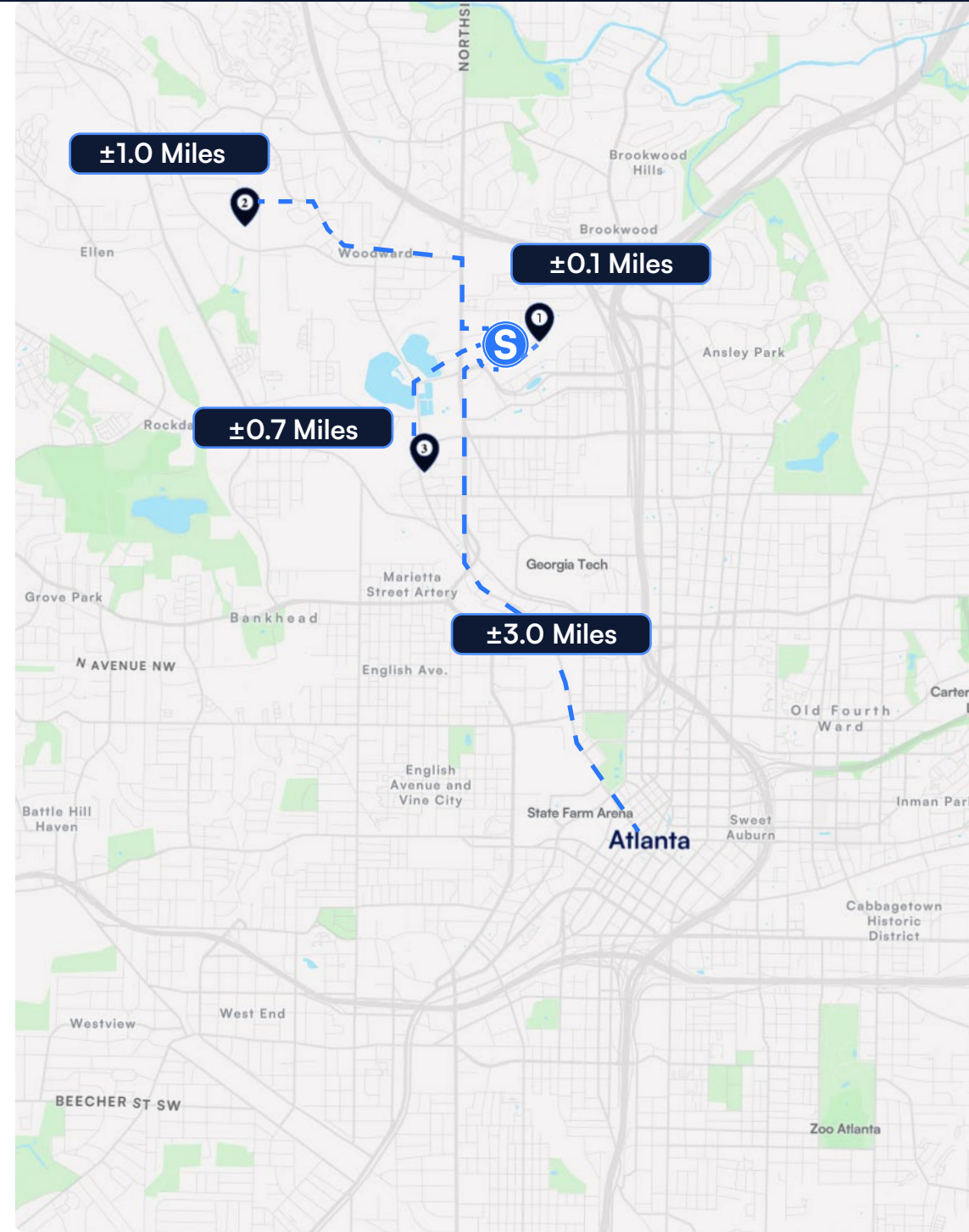

Atlanta, GA

The Atlanta MSA is one of the nation's most dynamic and resilient markets, supported by a diverse economy and its role as a hub for commerce, culture, and transportation. A strong tourism industry,

global corporate presence, and growing population continue to fuel demand for housing, making Atlanta a prime market for long-term investments.

Total Population
6,305,839

Annual Visitors
51 Million

Tourism Economic Impact
\$20 Billion

GDP
\$571+ Billion

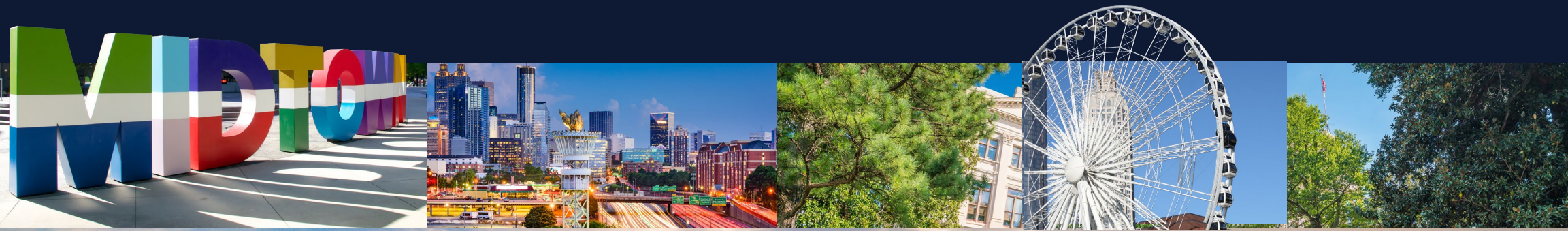

MATTHEWS™

Industrial/Redevelopment Opportunity

Atlanta, GA

Exclusively Listed By



Thomas Wilkinson
Senior Associate

(404) 348-4945

thomas.wilkinson@matthews.com

License No. 416083 (GA)



Harrison Auerbach
SVP & Director

(404) 445-1092

harrison.auerbach@matthews.com

License No. 451527 (GA)

Maxx Bauman | Broker of Record | Broker Firm No. 80041 (GA) | Broker License No. 451849 (GA)

This Offering Memorandum contains select information pertaining to the business and affairs of the property owner and its tenant for real property located at **465 Bishop St NW, Atlanta, GA, 30318** ("Property"). The Offering Memorandum may not be all-inclusive or contain all of the information a prospective purchaser may desire. The information contained in this Offering Memorandum is confidential and furnished solely for the purpose of a review by a prospective purchaser of the Property. It is not to be used for any other purpose or made available to any other person without the written consent of Seller or Matthews™. The material and information in the Offering Memorandum is unverified. Matthews™ has not made any investigation, and makes no warranty or representation, with respect to square footage, income and expenses, the future financial performance of the property, future rent, and real estate value market conditions, the condition or financial prospects of any tenant, or the tenants' plans or intentions to continue to occupy space at the property. All prospective purchasers should conduct their own thorough due diligence investigation of each of these areas with the assistance of their accounting, construction, and legal professionals, and seek expert opinions regarding volatile market conditions given the unpredictable changes resulting from the continuing COVID-19 pandemic. The information is based in part upon information supplied by the Owner and in part upon financial information obtained from sources the Owner deems reliable. Neither owner, nor their officers, employees, or real estate agents make any representation or warranty, express or implied, as to the accuracy or completeness of this Offering Memorandum, or any of its content, and no legal liability is assumed or shall be implied with respect thereto. Prospective purchasers should make their own projections and form their own conclusions without reliance upon the material contained herein.

By acknowledging your receipt of this Offering Memorandum for the Property, you agree:

1. The Offering Memorandum and its contents are confidential;
2. You will hold it and treat it in the strictest of confidence; and
3. You will not, directly or indirectly, disclose or permit anyone else to disclose this Offering Memorandum or its contents in any fashion or manner.

Matthews™ is not affiliated with, sponsored by, or endorsed by any commercial tenant or lessee in the Offering Memorandum. The presence of any entity's name or logo, including any commercial tenant's name or logo, is informational only and does not indicate or suggest any affiliation and/or endorsement of Matthews™, the property, or the seller by such entity.

Owner and Matthews™ expressly reserve the right, at their sole discretion, to reject any and all expressions of interest or offers to purchase the Property and to terminate discussions with any person or entity reviewing this Offering Memorandum or making an offer to purchase the Property unless and until a written agreement for the purchase and sale of the Property has been fully executed and delivered.

If you wish not to pursue negotiations leading to the acquisition of the Property or in the future you discontinue such negotiations, then you agree to purge all materials relating to this Property including this Offering Memorandum.

A prospective purchaser's sole and exclusive rights with respect to this prospective transaction, the Property, or information provided herein or in connection with the sale of the Property shall be limited to those expressly provided in an executed Purchase Agreement and shall be subject to the terms thereof. In no event shall a prospective purchaser have any other claims against Owner or Matthews™ or any of their affiliates or any of their respective officers, directors, shareholders, owners, employees, or agents for any damages, liability, or causes of action relating to this solicitation process or the marketing or sale of the Property.

This Offering Memorandum shall not be deemed to represent the state of affairs of the Property or constitute an indication that there has been no change in the state of affairs of the Property since the date of this Offering Memorandum.