

CARROLLTON RETAIL CENTER

3320 E HEBRON PKWY | CARROLLTON, TX 75010

AVAILABLE FOR LEASE
±1,840 SF

AVAILABLE FOR LEASE
±5,793 SF



CARROLLTON RETAIL CENTER

3320 E HEBRON PKWY | CARROLLTON, TX 75010

PROJECT SCOPE

- **Availability:**
 - ±1,840 SF Available (Former Elite Eyecare)
 - ±5,793 SF Available (Former BWW + Covered Patio)
- Great visibility and accessibility from Hebron Pkwy
- Close proximity to The Shops at Willow Bend, Prestonwood Baptist Church, and numerous national retailers including Costco, The Home Depot, and Hobby Lobby



Property Demographics

POPULATION	1-MILE	3-MILE	5-MILE
2025 Population	8,452	136,571	339,982
2025 Population	9,536	150,962	371,925
2030 Population Projection	10,749	169,263	412,302
Annual Growth 2020-2024	3.2%	2.6%	2.3%
Annual Growth 2024-2029	2.5%	2.4%	2.2%
HOUSEHOLDS	1-MILE	3-MILE	5-MILE
2025 Population	4,114	62,317	149,322
2025 Population	4,653	69,238	164,039
2030 Population Projection	5,259	77,806	182,126
2025 Population	3.3%	2.6%	2.6%
2030 Population Projection	2.6%	2.5%	2.2%
INCOME	1-MILE	3-MILE	5-MILE
Avg Household Income	\$128,977	\$124,395	\$130,340

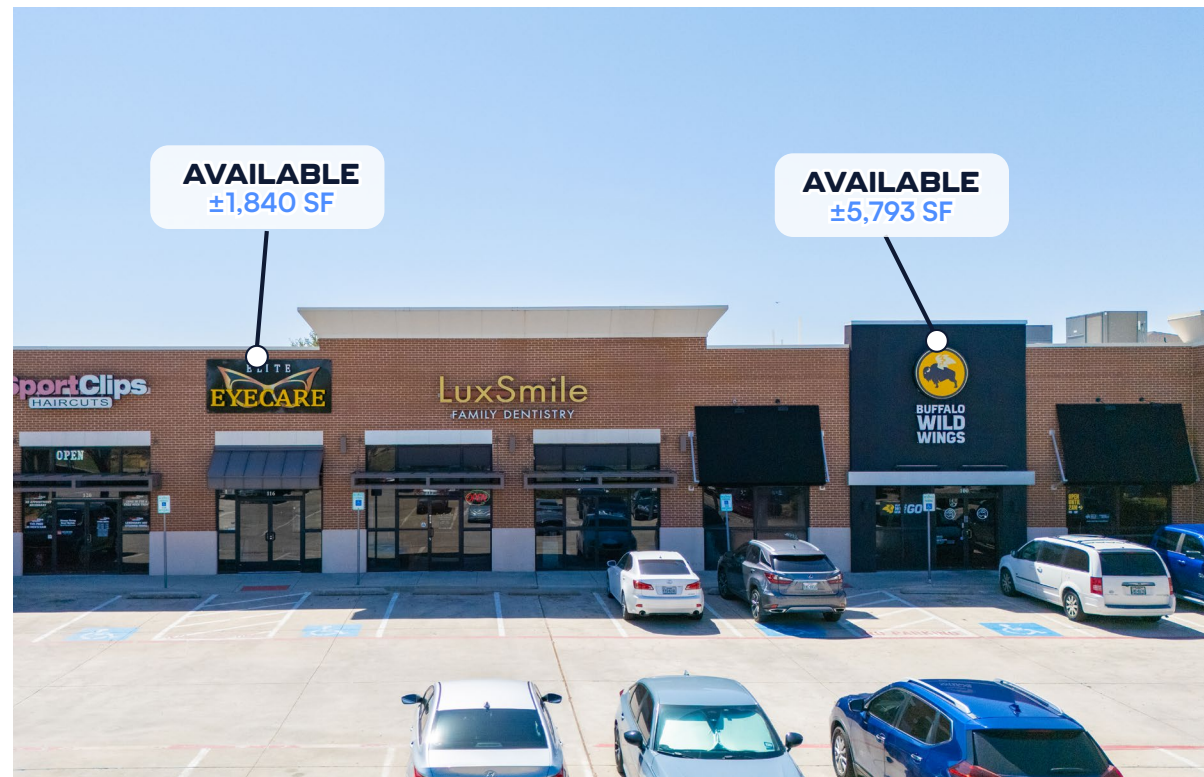

FLOOR PLAN | ELITE EYEWEAR

3320 E HEBRON PKWY | CARROLLTON, TX 75010

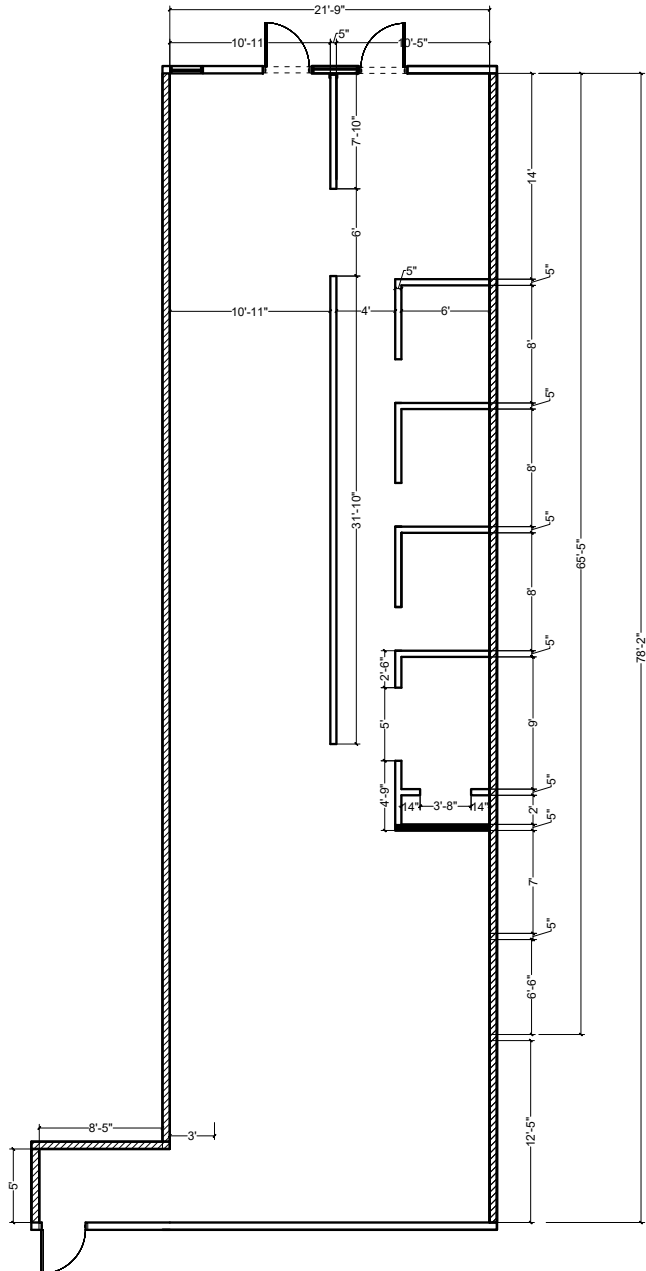

DIMENSIONED PLAN (for new walls)

SCALE: 1/8"=1'

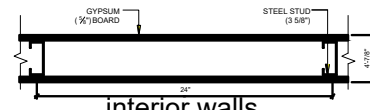

interior walls

SCALE: N.T.S.

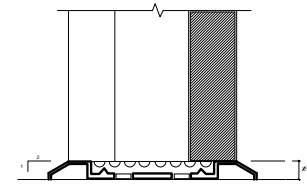

THRESHOLD AT DOORS

SCALE: N.T.S.

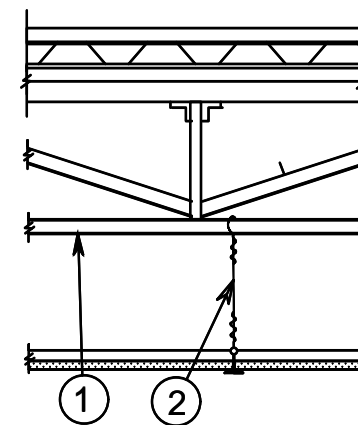

SUSPENDED HANGER WIRE

WALL TYPES :

- NEW INTERIOR WALL
- WALL ABOVE
- HALF WALL
- EXISTING INTERIOR WALL

NOTE : all interior walls 3/8 inch metal studs



COPYRIGHT COMPASS DESIGN INC.
THIS DOCUMENT IS THE PROPERTY OF THE
FIRM AND IS NOT TO BE REPRODUCED OR
TRANSMITTED IN ANY FORM OR BY ANY
METHODS, FOR ANY PURPOSE, WITHOUT PRIOR
WRITTEN PERMISSION FROM COMPASS DESIGN INC.

ELITE LUXE EYEWEAR

3320 East Hebron Pkwy #116
Carrollton Tx 75010

PROJ. NO. 22-1840

ISSUE DATE
April 19 2023

NO.	REVISION	DATE

DIMENSION PLAN

SHEET NUMBER

A3.0

COWBOY CHICKEN
WOOD FIRE ROTISSERIE

HOBBY LOBBY THE HOME DEPOT

COSTCO
WHOLESALE

Walmart
Supercenter



MAMA'S
DAUGHTERS DINER

WHATABURGER

TACO BELL



LA FITNESS

Sloane Street
±500 Units

Raising Cane's
CHICKEN FINGERS

FIVE GUYS
BURGERS and FRIES



Midway Rd ± 35,910 VPD

SHERWIN WILLIAMS

Bank OZK

Schlotzsky's

awake
BREAKFAST • LUNCH

E Hebron Pkwy ± 28,872 VPD



Sport Clips
HAIRCUTS

LuxSmile
FAMILY DENTISTRY
BY CARBONITE

Available
100
±5,793 SF

Covered Patio

Median Cut



POPEYES



Marsh Ln ± 12,042 VPD

Prestonwood Christian Academy
2,400 Students

Prestonwood Baptist Church
Annual Visitors: ±884,000

Subject Property

E Hebron Pkwy ± 28,872 VPD

RaceTrac
POTOTOS
GOLD STONE
DICKKEY'S BARBECUE PIT
DUNKIN'
POPEYES

Wylder Square
372 Units

benttree
Annual Visitors: ±150,000

amazon

Midway Rd ± 35,910 VPD

Sloane Street
500 Units

Prince of Peace Christian School
750 Students

Google Earth

Kwik-Kar
SONIC
Domino's
ADVANTAGE STORAGE
Total Wine & MORE
Michael's
planet fitness
Office DEPOT
ups
evo
QDOBA MEXICAN EATS
Planet Fitness
Crackin' Good
W

Dillas
FETITO
Cane's
TACO BELL
COWBOY CHICKEN
Cristina's

Avalon West Plano
568 Units

LAIFITNESS

Air Park-Dallas Airport

Plano PKWU ± 30,295 VPD

TRUIST
McDonald's
PET SMART
HOBBY LOBBY

macy's



+ Texas Health Presbyterian Hospital Plano
±563 Beds



🏠 Cortland Arbor Hills
±328 Units

+ LifeCare Hospitals of North Texas
±206 Beds

🏌️ The Clubs of Prestonwood
Golf Club

🎓 Renner Middle School
±1,225 Students

Parker Rd ± 29,712 VPD

Midway Rd ± 35,910 VPD

Dallas North Tollway ± 106,835 VPD

🎓 Hebron High School
±3,673 Students

The Shops at Willow Bend

🎓 Plano West Senior High
±2,620 Students

Neiman Marcus
Brooks Brothers
Dillard's Crate&Barrel

🏌️ Gleneagles
Country Club

🎓 Prestonwood Christian Academy
±2,400 Students

🏠 Atlas Point at Prestonwood
±138 Units

📍 Subject Property

E Hebron Pkwy ± 28,872 VPD

🏠 Wylder Square Apartments
±372 Units

🎓 Prince of Peace Christian School
±750 Students

🏠 The Brazos
±72 Units

✈️ Air Park-Dallas Airport
±0.5 Miles Away

The Landing
The Landing is a 300-acre, mixed-use corporate campus in North Dallas by Billingsley Company, offering office, retail, and residential spaces in a highly accessible, amenity-rich environment along the Dallas North Tollway

President George Bush Tpke ± 106,835 VPD

LEASING BROCHURE

CARROLLTON RETAIL CENTER

3320 E HEBRON PKWY | CARROLLTON, TX 75010

Grayson Duyck

FVP & ASSOCIATE DIRECTOR

(214) 295-4247

grayson.duyck@matthews.com

License No. 725363 (TX)

Baylor Worman

VICE PRESIDENT

(214) 227-2729

baylor.worman@matthews.com

License No. 784561 (TX)

Broker Of Record | Patrick Graham | License No. 528005 (TX) | Firm License No. 9005919 (TX)

This Leasing Package contains select information pertaining to the business and affairs of 3320 E Hebron Pkwy, Carrollton TX 75007 ("Property"). It has been prepared by Matthews™. This Leasing Package may not be all-inclusive or contain all of the information a prospective lessee may desire. The information contained in this Leasing Package is confidential and furnished solely for the purpose of a review by a prospective lessee of the Property. The material is based in part upon information supplied by the Owner. Owner, nor their officers, employees, or agents makes any representation or warranty, express or implied, as to the accuracy or completeness of this Leasing Package or any of its contents and no legal liability is assumed or shall be implied with respect thereto. Prospective lessees should make their own projections and form their own conclusions without reliance upon the material contained herein and conduct their own due diligence. Owner and Matthews™ expressly reserve the right, at their sole discretion, to reject any and all expressions of interest or offers to lease the Property and to terminate discussions with any person or entity reviewing this Leasing Package or making an offer to lease the Property unless and until a lease has been fully executed and delivered. In no event shall a prospective lessee have any other claims against Owner or Matthews™ or any of their affiliates or any of their respective officers, Directors, shareholders, owners, employees, or agents for any damages, liability, or causes of action relating to this solicitation process or the marketing of the Property. This Leasing Package shall not be deemed to represent the state of affairs of the Property or constitute an indication that there has been no change in the state of affairs of the Property since the date this Leasing Package.



Information About Brokerage Services

Texas law requires all real estate license holders to give the following information about brokerage services to prospective buyers, tenants, sellers and landlords.

11-2-2015



TYPES OF REAL ESTATE LICENSE HOLDERS:

- A **BROKER** is responsible for all brokerage activities, including acts performed by sales agents sponsored by the broker.
- A **SALES AGENT** must be sponsored by a broker and works with clients on behalf of the broker.

A BROKER'S MINIMUM DUTIES REQUIRED BY LAW (A client is the person or party that the broker represents):

- Put the interests of the client above all others, including the broker's own interests;
- Inform the client of any material information about the property or transaction received by the broker;
- Answer the client's questions and present any offer to or counter-offer from the client; and
- Treat all parties to a real estate transaction honestly and fairly.

A LICENSE HOLDER CAN REPRESENT A PARTY IN A REAL ESTATE TRANSACTION:

AS AGENT FOR OWNER (SELLER/LANDLORD): The broker becomes the property owner's agent through an agreement with the owner, usually in a written listing to sell or property management agreement. An owner's agent must perform the broker's minimum duties above and must inform the owner of any material information about the property or transaction known by the agent, including information disclosed to the agent or subagent by the buyer or buyer's agent.

AS AGENT FOR BUYER/TENANT: The broker becomes the buyer/tenant's agent by agreeing to represent the buyer, usually through a written representation agreement. A buyer's agent must perform the broker's minimum duties above and must inform the buyer of any material information about the property or transaction known by the agent, including information disclosed to the agent by the seller or seller's agent.

AS AGENT FOR BOTH - INTERMEDIARY: To act as an intermediary between the parties the broker must first obtain the written agreement of *each party* to the transaction. The written agreement must state who will pay the broker and, in conspicuous bold or underlined print, set forth the broker's obligations as an intermediary. A broker who acts as an intermediary:

- Must treat all parties to the transaction impartially and fairly;
- May, with the parties' written consent, appoint a different license holder associated with the broker to each party (owner and buyer) to communicate with, provide opinions and advice to, and carry out the instructions of each party to the transaction.
- Must not, unless specifically authorized in writing to do so by the party, disclose:
 - that the owner will accept a price less than the written asking price;
 - that the buyer/tenant will pay a price greater than the price submitted in a written offer; and
 - any confidential information or any other information that a party specifically instructs the broker in writing not to disclose, unless required to do so by law.

AS SUBAGENT: A license holder acts as a subagent when aiding a buyer in a transaction without an agreement to represent the buyer. A subagent can assist the buyer but does not represent the buyer and must place the interests of the owner first.

TO AVOID DISPUTES, ALL AGREEMENTS BETWEEN YOU AND A BROKER SHOULD BE IN WRITING AND CLEARLY ESTABLISH:

- The broker's duties and responsibilities to you, and your obligations under the representation agreement.
- Who will pay the broker for services provided to you, when payment will be made and how the payment will be calculated.

LICENSE HOLDER CONTACT INFORMATION: This notice is being provided for information purposes. It does not create an obligation for you to use the broker's services. Please acknowledge receipt of this notice below and retain a copy for your records.

Matthews Real Estate Investment Services, Inc.	9005919	transactions@matthews.com	866-889-0050
Licensed Broker /Broker Firm Name or Primary Assumed Business Name	License No.	Email	Phone
Patrick Graham	528005	licensing@matthews.com	866-889-0050
Designated Broker of Firm	License No.	Email	Phone
Patrick Graham	528005	licensing@matthews.com	866-889-0050
Licensed Supervisor of Sales Agent/ Associate	License No.	Email	Phone
Sales Agent/Associate's Name	License No.	Email	Phone

Buyer/Tenant/Seller/Landlord Initials

Date